



STUBBE'S
PRECAST

Family Owned.
Professionally Run.



Residential Applications

Why Choose Hollowcore for Your Home



Strength

High resistance to impact, able to handle heavy loading



Speed

Most projects installed in 1-day with Stubbe's Precast in house, non-union crews



Versatility

Garage floor structure allows for usable space underneath. As indoor flooring system, hollowcore can cantilever out for a patio without the need for posts. Has excellent thermal mass for in-floor heating and superior sound resistance with STC rating of 50+



Length

Various lengths achievable; optimal for an open basement



Approval

Manufactured in CPCI certified facilities in a controlled environment which ensures tighter tolerances and higher quality products



Hollowcore Maximum Span Lengths:

8" thick	30'-0"
10" thick	38'-0"
12" thick	42'-0"

- Based on a garage floor design with assumed uniformly distributed dead load for 52 PSF and live load of 50 PSF

Costing Case Study

Unfinished space based on a garage area of 500sq.ft.q

Hollowcore supplied and installed= \$12,500.00 - \$25/sf

Thicker foundation, w/ ledge to support hollowcore= \$5,000.00 - \$10/sf

Membrane between hollowcore and concrete garage floor= \$1,500.00 - \$3/sf

Rebar reinforcing to prevent cracking= \$750.00 - \$1.5/sf

TOTAL UP CHARGE OVER GARAGE AREA: \$19,750.00 - \$39.50/SF

(GARAGE AREA ONLY)

*The sq.ft cost will decrease the higher the floor area



Frequently Asked Questions

What drawings do the owner/ contractor need to provide?

What drawings do Stubbe's Precast provide?

Home owner provides section drawings showing bearing location of precast and floor plans with all dimensions of supporting walls/ beams for the area that is to receive precast (designed by others).

Stubbe's precast will provide engineered shop drawings showing the hollowcore layout and connections. Additional engineering for the walls may be required.

What amount of bearing do I need?

Stubbe's Precast requires 4" of bearing on concrete/ block walls and requires 3 1/2" of bearing on steel beams.

Are hollowcore slabs sloped?

No, produced with a uniform thickness. If a slope is desired it can be achieved by having different bearing heights, or by a concert topping. Hollowcore will have camber.

What type of finish is on the underside of the hollowcore?

Stubbe's Precast hollowcore slabs come with a standard steel form finish on the underside.

What are typical lead times for hollow core installation?

It commonly takes 10- 12 weeks after the acceptance of the contract.

What is a typical waterproofing detail?

See diagram.

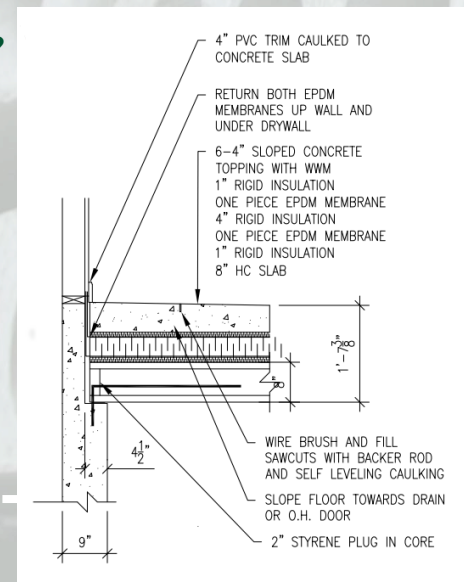

Contact us for a quote and additional information.



STUBBE'S
PRECAST

STUBBE'S PRECAST
44 Muir Line, Harley, NOE 1EO
519-424-2183
estimating@stubbes.org